

M6 Knurled Nut Included
(not installed)

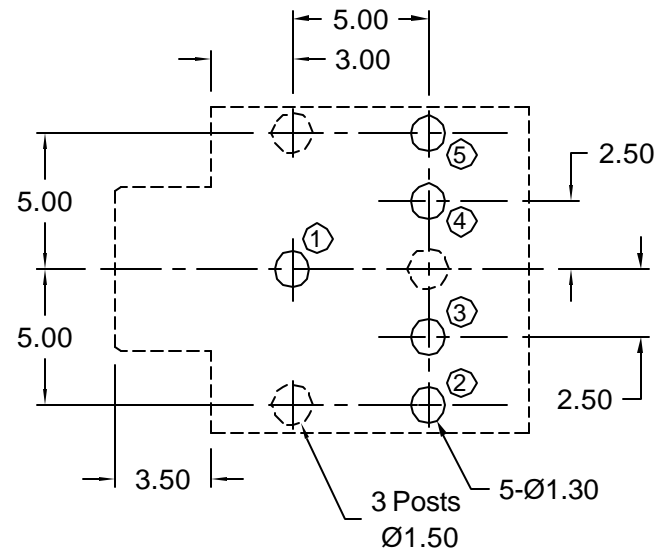
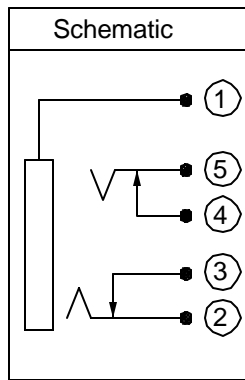
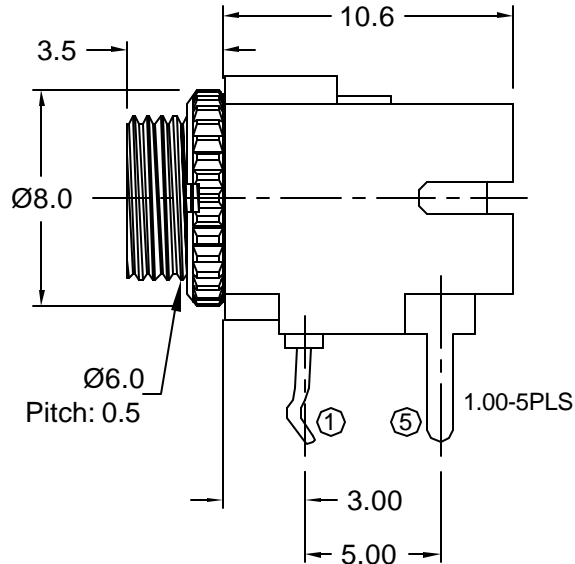
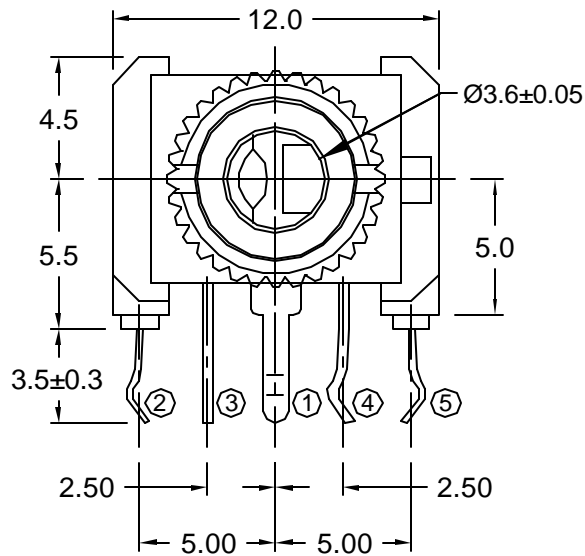

PCB LAYOUT
(BOTTOM VIEW)

Materials and Finish

Housing: PBT Thermoplastic
30% Glass Filled, Black
UL 94V-0 Rated

Terminals:

Pin #1 : SPCC, Nickel Plated

Pin #5 & Pin #2 Contacts:
Phosphor Bronze, Tin Plated

Pin #3 and Pin #4 terminals:
Brass, tin plated

Bushing: Brass, Nickel plated

Mechanical Characteristics

Insertion Force:
0.4kg - 2.0kg

Extraction Force:
0.3kg - 2.0kg

Durability: 5000 mating cycles

Electrical Characteristics

Contact Resistance:
Before Test: 30mohms Max.
After Durability Test:
60 mohms Max.

Insulation Resistance:
More than 100 Megohms
at 250V DC

Dielectric Strength for 1 minute

Operating Temp:
-25°C to +80°C



Tolerances

X.X ± 0.25
X.XX ± 0.15
Unless Stated
Otherwise



REV.	DATE	DESCRIPTION	REV. BY	CHK. BY	DRAWN BY	DATE
A1	9/6/05	New Drawing	R. Aguirre	H. MA	R. Aguirre	07/13/05
A2	11/8/06	ECO 06-046	R. Aguirre	H. MA		

STX-3100-5C

3.5mm Stereo Jack ,RoHS Compliant
One Single Throw Double Pole Switch

